

Class G Trench Grate and Frame

MEA Drainage systems

Ductile Iron Slotted Trench Grate & Frame

AS3996 Load Class G900, point load approximately 30,000kg.
Compliant for wheelchair and walking cane safety AS1428.2.
Compliant for bicycle tyre penetration AS3996.

Intake area of 583,600mm² per two metre frame. Manufactured from ductile iron with KTL coating.
Frame constructed from cast iron edge rail system. Standard 4-point bolt locking mechanisms offer securement to frames.



PRODUCT SPECIFICATION

DESCRIPTION	MATERIAL	LENGTH	PRODUCT CODE	WEIGHT (KG)
300mm Clear Opening Ductile Iron Trench Frame 2m Long	Ductile Iron	2,000mm	300CIF	15
322mm Ductile Iron Slotted Grate 0.5m Class G (4 required per frame)	Ductile Iron	498mm	154853	24.8
4-point Bolt Locking System (8 bolts per pack=1 metre)	Stainless Steel	N/A	153050	0.2

Grate and Frame Plan View:

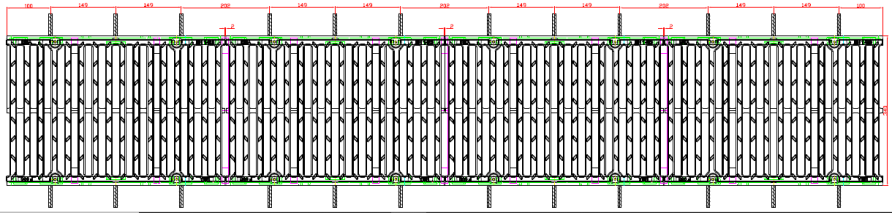

Frame Section View:

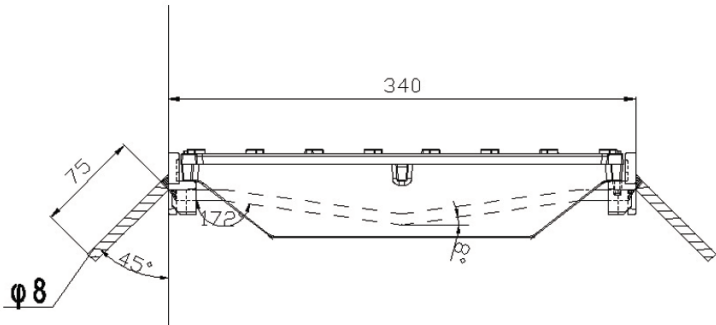

Recommended Installation Method:

