

150mm Clear Opening Ductile Iron Slotted Trench Grate & Frame - Class E

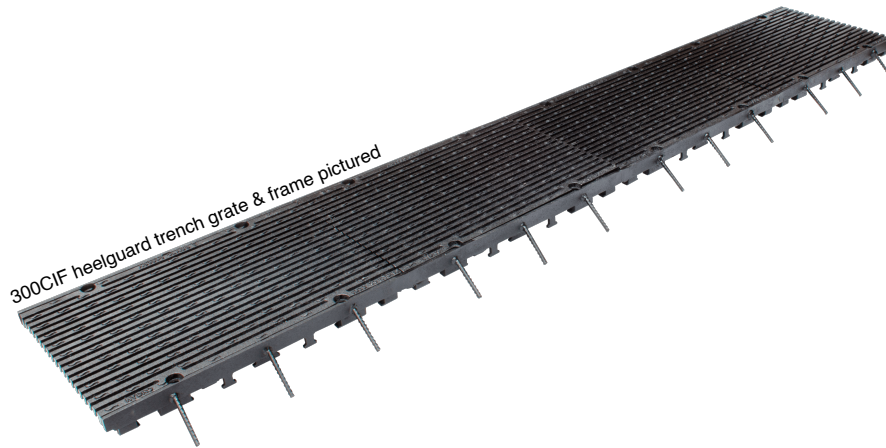

Ductile Iron Longitudinal Heelguard Grate CLIPFIX

Certifies to AS3996:2019 load class E400kN, point load approximately 13,700kg.
Compliant for wheelchair & walking cane safety AS1428.2.
Compliant for bicycle tyre penetration AS3996:2019.

Intake are of approximately 137,764mm² per two metre length.
Manufactured from ductile iron with KTL coating.
Frames constructed from the same edge rails from MEA's Supreme "C" series channels.

Locking Mechanism

Standard 4 point bolt locking system offers securement for the grates to the frames.

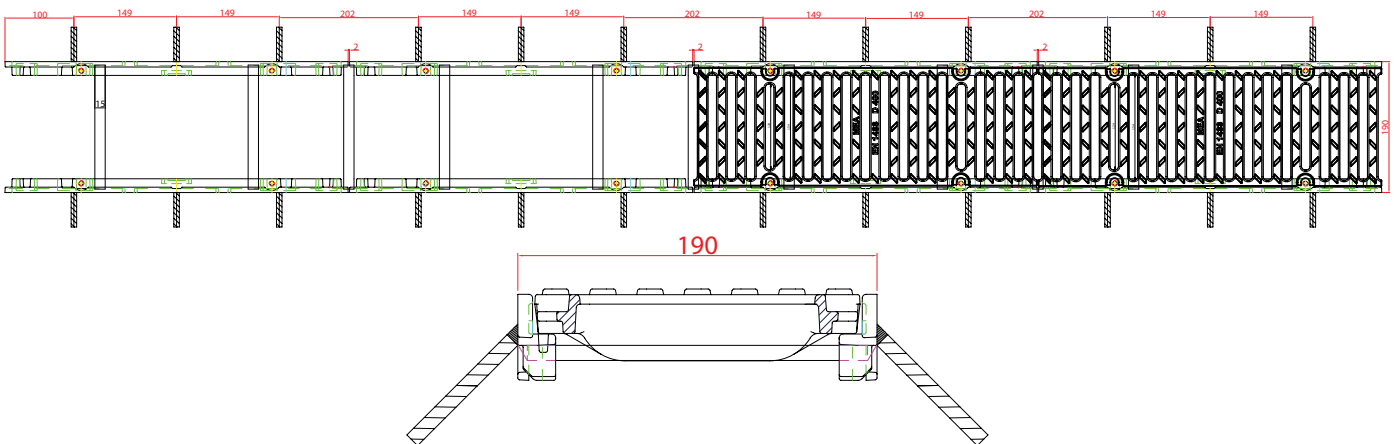

PRODUCT SPECIFICATION

DESCRIPTION	MATERIAL	LENGTH	PART NO.	WEIGHT (kg)
150mm Clear Opening Ductile Iron Trench Frame (2 Metres Long)	Ductile Iron	2,000mm	150C1F	10.0
172mm Ductile Iron Slotted Grate 0.5m Class E (4 required per frame)	Ductile Iron	498mm	151173	6.2
4 Point Locking Bolt Pack (8 Bolts Per Pack, 2 Packs Required Per Frame)	Stainless Steel	N/A	153050	0.2